



TY96/96A and TY97/97A VHF Radio Installation Manual



01238-00-AE

22 June 2017

Trig Avionics Limited
Heriot Watt Research Park
Riccarton, Currie
EH14 4AP
Scotland, UK

Copyright Trig Avionics Limited, 2015

This page intentionally left blank

CONTENTS

1. PREFACE	1
1.1 PURPOSE.....	1
1.2 SCOPE.....	1
1.3 CHANGES FROM PREVIOUS ISSUE.....	1
1.4 DOCUMENT CROSS-REFERENCES.....	1
2. INTRODUCTION	2
2.1 TY96 AND TY97 DESCRIPTION.....	2
2.2 INTERFACES.....	2
3. TECHNICAL SPECIFICATIONS	3
3.1 TY96 VHF RADIO (TRIG PART NUMBER 01226-00-01).....	3
3.2 TY97 VHF RADIO (TRIG PART NUMBER 01228-00-01).....	3
3.3 TY96A VHF RADIO (TRIG PART NUMBER 01787-00-01).....	4
3.4 TY97A VHF RADIO (TRIG PART NUMBER 01789-00-01).....	5
3.5 PHYSICAL SPECIFICATIONS (IN TRAY).....	5
3.6 LOW VOLTAGE OPERATION.....	5
3.7 INSTALLATION APPROVAL.....	6
4. UNIT AND ACCESSORIES SUPPLIED	7
4.1 TY96 VHF RADIO ITEMS.....	7
4.2 TY96A VHF RADIO ITEMS.....	7
4.3 TY97 VHF RADIO ITEMS.....	7
4.4 TY97A VHF RADIO ITEMS.....	7
4.5 INSTALLATION KIT.....	8
4.6 REQUIRED ITEMS.....	8
5. INSTALLATION	9
5.1 UNPACKING AND INSPECTING EQUIPMENT.....	9
5.2 INSTALLATION OVERVIEW.....	9
5.3 COOLING REQUIREMENTS.....	10
5.4 ELECTRICAL CONNECTIONS.....	10
5.4.1 <i>Orientation Diagram</i>	11
5.4.2 <i>D Connector Crimp Terminals</i>	11
5.4.3 <i>Power and Ground Wiring</i>	12
5.4.4 <i>Stereo Wiring Considerations</i>	12
5.4.5 <i>Mono Wiring Considerations</i>	12
5.4.6 <i>Audio Wiring</i>	12
5.4.7 <i>Example Wire Harness</i>	14
5.5 ANTENNA INSTALLATION.....	14
5.5.1 <i>Antenna Ground Plane</i>	15
5.5.2 <i>Antenna Cable</i>	15

5.5.3	<i>BNC Connection</i>	15
5.6	INTERFACE DETAILS.....	16
5.6.1	<i>Speaker Output</i>	16
5.6.2	<i>Headphone Outputs</i>	16
5.6.3	<i>Mono Audio Output</i>	16
5.6.4	<i>Transmit Interlock</i>	16
5.6.5	<i>Lighting Bus Input</i>	16
5.6.6	<i>PTT1/2 Key Input</i>	16
5.6.7	<i>Intercom Key Input</i>	16
5.6.8	<i>Auxiliary Audio Input</i>	17
5.6.9	<i>Music Audio Input</i>	17
5.6.10	<i>Microphone Input</i>	17
5.6.11	<i>RS232 Input/Output</i>	17
5.6.12	<i>Remote Flip-Flop</i>	17
5.6.13	<i>Power Input</i>	17
5.6.14	<i>Ground Returns</i>	17
6.	INSTALLATION SETUP AND TEST	18
6.1	INITIAL POWER ON.....	18
6.2	CONFIGURATION ITEMS.....	18
6.2.1	<i>Intercom Volume</i>	18
6.2.2	<i>Intercom Squelch</i>	18
6.2.3	<i>Music Volume</i>	18
6.2.4	<i>Music Muting</i>	18
6.2.5	<i>Frequency Step Size</i>	19
6.2.6	<i>Auxiliary Input Volume</i>	19
6.2.7	<i>Auxiliary Input Muting</i>	19
6.2.8	<i>Sidetone Volume</i>	19
6.2.9	<i>Receiver Squelch Offset</i>	19
6.2.10	<i>Audio Test Tones</i>	19
6.2.11	<i>Microphone gain adjustment</i>	19
6.2.12	<i>LCD Dim Point</i>	19
6.2.13	<i>LCD Brightness Curve</i>	20
6.2.14	<i>Single PTT Mode</i>	20
7.	POST INSTALLATION CHECKS	21
8.	NORMAL OPERATION	22
8.1	OVERVIEW.....	22
8.2	DISPLAY.....	22
8.3	ON/OFF VOLUME KNOB.....	22
8.4	TUNING KNOBS.....	22

8.5	FLIP-FLOP BUTTON.....	22
8.6	MON BUTTON.....	23
8.7	MEM BUTTON	23
8.8	PLAY BUTTON	23
8.9	EMER BUTTON.....	23
8.10	SAVING AND LOADING THE FREQUENCY DATABASE.....	23
8.11	GENERAL LOW TEMPERATURE OPERATION	23
8.12	WARNING MESSAGES	23
8.13	FAULT ANNUNCIATION	24
9.	CONTINUED AIRWORTHINESS	25
9.1	CLEANING THE FRONT PANEL	25
10.	LIMITED WARRANTY.....	26
11.	ENVIRONMENTAL QUALIFICATION FORMS.....	27
12.	INSTALLATION DRAWINGS	31
13.	WIRING DIAGRAMS	33
14.	USB FILE FORMAT	39
14.1	USB COMPATIBILITY	40

1. Preface

1.1 Purpose

This manual describes the physical and electrical characteristics and the installation requirements for a TY96 or TY97 VHF and TY96A or TY97A VHF radio.

1.2 Scope

This Manual applies to the installation of the TY96, TY97 and TY96A, TY97A VHF radio.

At the publication date of this manual the software version identifier for the TY96/TY97 is 1.6 and the FPGA version identifier is 1.1. The software and FPGA versions are subject to change without notice.

1.3 Changes from Previous Issue

Minor spelling and grammar changes	Throughout
Addition of TY96A and TY97A 25KHz variants.	Throughout
Changed pin 7 name to 'Mono Audio Out'	Section 5.4
Added brief explanation of L, R audio positioning	Section 5.4.4
Corrected error in section 6.1 that states 'TC90' rather than TY96	Section 6.1
Added COG (centre of gravity) position to installation drawing	Section 12
Correction to diagram 5 for BK197A remote transfer interface	Section 12
Addition of wiring harness connector pin view to wiring drawings	Section 12

1.4 Document Cross-References

01239-00	TY96 TY96A and TY97 TY97A VHF Radio Operating Manual	AC
ETSO 2C169a	VHF Radio communication receiving equipment operating within the radio frequency range 117.875 – 137 MHz	EASA
TSO C169a	Minimum Operational Performance standards for Airborne Radio Communications equipment standards	FAA
ETSO 2C128	Devices that prevent blocked channels used in two-way radio communications due to unintentional transmissions	EASA
TSO C128a	Equipment that prevents blocked channels used in two-way radio communications due to unintentional transmissions	FAA

2. Introduction

2.1 TY96 and TY97 Description

The TY96 and TY97 VHF radio systems are ED-23C compliant class C (25 kHz offset carrier) and class H1 and H2 (8.33 kHz offset carrier) VHF radios. The TY96 has a nominal power output of 10 watts, and meets the power output requirements for Class 3 and Class 5. The TY97 has a nominal power output of 16 watts, and meets the power output requirements for Class 3 and Class 5. The TY96 and TY97 are certified to ETSO 2C169a, 2C128a, TSO C169a and TSO C128a.

The TY96A and TY97A are variants that use 25 KHz channel spacing and are ED-23C compliant class C (25 kHz offset carrier) VHF radios. The TY96A has a nominal power output of 10 watts, and meets the power output requirements for Class 4. The TY97A has a nominal power output of 16 watts, and meets the power output requirements for Class 3. The TY96A and TY97A are certified to ETSO 2C169a, 2C128a, TSO C169a and TSO C128a.

Other than the difference in channel spacing the TY96A/97A variants are identical and all references to the TY96/97 also apply to the TY96A/97A unless otherwise stated.

The TY96 can be powered from either a 14 volt nominal or 28 volt nominal DC power supply with no configuration changes required. The TY97 requires a 28 volt nominal DC power supply.

2.2 Interfaces

At the rear, the VHF radio unit has a 25 way D-type connector and single antenna connector for blind mating with the corresponding connectors in the mounting tray. The 25 way D-type interface provides the following services:

INPUTS

Power input	The TY96 operates on 11 to 33 volts DC. The TY97 operates on 22 to 33 volts DC.
Lighting bus input	Connects to the aircraft lighting bus and is used to adjust the switch lighting intensity.
RS232 input	An optional input to allow preloading of frequencies, generally from a GPS.
Push-to-talk inputs	There are two push to talk inputs corresponding to the two microphones. For backward compatibility with older installations both microphones can optionally be gated by a single PTT input.
External flip-flop input	An optional keyswitch input to enable remote transfer of primary and secondary frequencies
Intercom keyswitch	An optional input to allow the intercom to be switch controlled.
Microphone inputs	There are two microphone inputs, suitable for conventional aircraft microphones.
Auxiliary audio input	A single connection to allow audio annunciators or ident tones to be routed to the headphones and speaker. Auxiliary audio input is not routed to Mono Audio output.
Music audio input	A two channel music input to allow connection of a stereo audio signal of 1.5Vrms into a 600 ohms load. Audio is routed to the headphones only.

OUTPUTS

Speaker output	A speaker output suitable for a cabin speaker with impedance of 4 ohms or greater.
Headphone outputs	Two stereo headphone outputs suitable for conventional aircraft headsets with impedance in the region of 150 – 600 ohms.
Mono Audio output	A mono audio output designed to connect to an aircraft audio panel with an impedance of 600 ohms; outputs Rx and sidetone only.

3. Technical Specifications

3.1 TY96 VHF Radio (Trig Part Number 01226-00-01)

Specification	Characteristics
Compliance	ETSO 2C169a Class C, E, H1, H2, 4, 6, ETSO 2C128, TSO C169a Class C, E, 4, 6, TSO C128a
FCC Identification	VZI01228
Applicable documents	EUROCAE ED-23C, EUROCAE ED-67, EUROCAE ED-14F (RTCA DO-160F), RTCA DO-186B, RTCA DO-207
Software	ED-12B (RTCA DO-178B) Level B
Power Requirements	11 – 33 volts DC. Typical 6.3 watts @ 14 volts.
Altitude	55,000 feet
Humidity	95% @ +50C for 6 hours; 85% @ +38C for 16 hours. Tested to Category A in DO-160G
Operating Temperature	-20C to +55C
Transmitter Frequency	118.000 MHz to 136.992 MHz; 760 channels at 25 kHz spacing, 2280 channels at 8.33 kHz spacing.
Transmitter Power	10 watts nominal carrier power
Transmitter Modulation	5K6 A3E
Stuck-mic timeout	35 seconds
Transmitter Duty Cycle	100% transmit is possible (subject to stuck mic timeout)
Receiver Frequency	118.000 MHz to 136.992 MHz; 760 channels at 25 kHz spacing, 2280 channels at 8.33 kHz spacing.
Receiver Sensitivity	< 5uV for 6 dB SINAD
AGC Characteristic	< 6dB variation 5 uV to 100 mV EMF

3.2 TY97 VHF Radio (Trig Part Number 01228-00-01)

Specification	Characteristics
Compliance	ETSO 2C169a Class C, E, H1, H2, 3, 5, ETSO 2C128, TSO C169a Class C, E, 3, 5, TSO C128a
FCC Identification	VZI01228
Applicable documents	EUROCAE ED-23C, EUROCAE ED-67, EUROCAE ED-14F (RTCA DO-160F), RTCA DO-186B, RTCA DO-207
Software	ED-12B (RTCA DO-178B) Level B
Power Requirements	22 – 33 volts DC. Typical 6.3 watts @ 28 volts.
Altitude	55,000 feet
Humidity	95% @ +50C for 6 hours; 85% @ +38C for 16 hours. Tested to Category A in DO-160G
Operating Temperature	-20C to +55C
Transmitter Frequency	118.000 MHz to 136.992 MHz; 760 channels at 25 kHz spacing, 2280 channels at 8.33 kHz spacing.

Transmitter Power	16 watts nominal carrier power
Transmitter Modulation	5K6 A3E
Stuck-mic timeout	35 seconds
Transmitter Duty Cycle	25%
Receiver Frequency	118.000 MHz to 136.992 MHz; 760 channels at 25 kHz spacing, 2280 channels at 8.33 kHz spacing.
Receiver Sensitivity	< 5uV for 6 dB SINAD
AGC Characteristic	< 6dB variation 5 uV to 100 mV EMF

3.3 TY96A VHF Radio (Trig Part Number 01787-00-01)

Specification	Characteristics
Compliance	ETSO 2C169a Class C, 4, ETSO 2C128, TSO C169a Class C, 4, TSO C128a
FCC Identification	VZI01228
Applicable documents	EUROCAE ED-23C, EUROCAE ED-67, EUROCAE ED-14F (RTCA DO-160F), RTCA DO-186B, RTCA DO-207
Software	ED-12B (RTCA DO-178B) Level B
Power Requirements	11 – 33 volts DC. Typical 6.3 watts @ 14 volts.
Altitude	55,000 feet
Humidity	95% @ +50C for 6 hours; 85% @ +38C for 16 hours. Tested to Category A in DO-160G
Operating Temperature	-20C to +55C
Transmitter Frequency	118.000 MHz to 136.992 MHz; 760 channels at 25 kHz spacing.
Transmitter Power	10 watts nominal carrier power
Transmitter Modulation	5K6 A3E
Stuck-mic timeout	35 seconds
Transmitter Duty Cycle	100% transmit is possible (subject to stuck mic timeout)
Receiver Frequency	118.000 MHz to 136.992 MHz; 760 channels at 25 kHz spacing.
Receiver Sensitivity	< 5uV for 6 dB SINAD
AGC Characteristic	< 6dB variation 5 uV to 100 mV EMF

3.4 TY97A VHF Radio (Trig Part Number 01789-00-01)

Specification	Characteristics
Compliance	ETSO 2C169a Class C, 3, ETSO 2C128, TSO C169a Class C, 3, TSO C128a
FCC Identification	VZI01228
Applicable documents	EUROCAE ED-23C, EUROCAE ED-67, EUROCAE ED-14F (RTCA DO-160F), RTCA DO-186B, RTCA DO-207
Software	ED-12B (RTCA DO-178B) Level B
Power Requirements	22 – 33 volts DC. Typical 6.3 watts @ 28 volts.
Altitude	55,000 feet
Humidity	95% @ +50C for 6 hours; 85% @ +38C for 16 hours. Tested to Category A in DO-160G
Operating Temperature	-20C to +55C
Transmitter Frequency	118.000 MHz to 136.992 MHz; 760 channels at 25 kHz spacing.
Transmitter Power	16 watts nominal carrier power
Transmitter Modulation	5K6 A3E
Stuck-mic timeout	35 seconds
Transmitter Duty Cycle	25%
Receiver Frequency	118.000 MHz to 136.992 MHz; 760 channels at 25 kHz spacing.
Receiver Sensitivity	< 5uV for 6 dB SINAD
AGC Characteristic	< 6dB variation 5 uV to 100 mV EMF

3.5 Physical Specifications (in Tray)

The TY96 and TY97 are the same size and weight.

Specification	Characteristics
Height	33 mm (1.30")
Width	159 mm (6.25")
Length	231 mm (9.1") behind the panel 273 mm (10.77") overall
Weight	2.33lbs. (1.06Kg)

3.6 Low Voltage Operation

Normal operating voltage for the TY96 is any voltage between 11 and 33 volts, whilst normal operating voltage for the TY97 is any voltage between 22 and 33 volts. At these voltages all functions behave normally, and transmitter power meets the applicable Class requirements of ED-23C.

The radio will continue to operate at a lower voltage than these ranges. As the available voltage falls, the transmitter output power will be reduced, and at 9 volts the nominal transmitter power will be approximately 2.5 watts. The transmitter will be inhibited below 8 volts.

The receiver also works below the nominal voltage. All receiver functions will work normally, but as a

safety feature to preserve battery power in an emergency, at 10 volts or below the available speaker volume will reduce.

In addition a warning message, “Low Volts”, will be displayed on the screen when the bus voltage falls below 10 volts in a TY96, or 18 volts in a TY97.

3.7 Installation Approval

The conditions and tests required for the TSO approval of the TY96 and TY97 VHF radios are minimum performance standards. It is the responsibility of those installing this VHF radio on or within a specific type or class of aircraft to determine that the aircraft operating conditions are within the TSO standards. The VHF radio may be installed only if further evaluation by the user/installer documents an acceptable installation that is approved by the appropriate airworthiness authority.

4. Unit and Accessories supplied

4.1 TY96 VHF radio Items

The TY96 VHF radio includes the following items:

Unit Description	Qty	Part Number
TY96 VHF Radio	1	01226-00-01
TY96/TY97 Installation Kit	1	01472-00
TY96/TY97 Mounting Tray	1	01368-00
TY96 TY96A and TY97 TY97A Pilots Operating Handbook	1	01239-00

4.2 TY96A VHF radio Items

The TY96A VHF radio includes the following items:

Unit Description	Qty	Part Number
TY96A VHF Radio	1	01787-00-01
TY96/TY97 Installation Kit	1	01472-00
TY96/TY97 Mounting Tray	1	01368-00
TY96 TY96A and TY97 TY97A Pilots Operating Handbook	1	01239-00

4.3 TY97 VHF radio Items

The TY97 VHF radio includes the following items:

Unit Description	Qty	Part Number
TY97 VHF Radio	1	01228-00-01
TY96/TY97 Installation Kit	1	01472-00
TY96/TY97 Mounting Tray	1	01368-00
TY96 TY96A and TY97 TY97A Pilots Operating Handbook	1	01239-00

4.4 TY97A VHF radio Items

The TY97A VHF radio includes the following items:

Unit Description	Qty	Part Number
TY97 VHF Radio	1	01789-00-01
TY96/TY97 Installation Kit	1	01472-00
TY96/TY97 Mounting Tray	1	01368-00
TY96 TY96A and TY97 TY97A Pilots Operating Handbook	1	01239-00

4.5 Installation Kit

The TY96/TY97 installation kit includes the following items:

Unit Description	Qty	Part Number
Connector Mounting Plate	1	01369-00
Connector Standard Mount 25 Way D receptacle to M24308	1	00866-00
Crimp Socket Contact, Wire size 20-24 AWG	25	00730-00
D-Sub Shell	1	01440-00
D-Sub Shell Clamp	1	01441-00
D-Sub Shell Cover	1	01442-00
BNC Female to Blind Mate Adaptor	1	01410-00
Washer, 7/16", Plain, Stainless Steel	1	00241-00
Circlip, 7/16", External, Stainless Steel	1	00242-00
Washer, 7/16", Wave, Stainless Steel	1	00317-00
Screw, Pozidrive, Csk Head, M2.5 x 5mm, Pre Patch	2	01020-00
Screw, Pozidrive, Pan Head, M2.5 x 5mm, Pre Patch	6	01021-00
Screw, Pozidrive, Pan Head, M2.5 x 8mm, Pre Patch	4	01024-00
Screw, Philips Csk head, 4-40 UNC x 0.312", Pre Patch	2	01397-00
Washer, M2.5 Rect Sect, Spring	6	01473-00
User Label Sheet	1	01412-00
USB Flash Drive	1	01646-00

4.6 Required Items

Additional items you will require, but which are not in the TY96/TY97 package, include:

- Antenna and fixing hardware. The TY96 or TY97 are compatible with any standard 50 ohm vertically polarised antenna with a VSWR better than 2.5:1.
- Cables. You need to supply and fabricate all required cables. Guidance on cable types is given in section 5.
- Fixings. To secure the VHF radio tray to the airframe you will need at least 6 flat head screws and self-locking nuts. If the aircraft does not have existing mounting provisions you may need to fabricate additional brackets to support the VHF radio tray.

5. Installation

5.1 Unpacking and Inspecting Equipment

Carefully unpack the VHF radio and make a visual inspection of the unit for evidence of any damage incurred during shipment. If the unit is damaged, notify the shipping company to file a claim for the damage. To justify your claim, save the original shipping container and all packaging materials.

5.2 Installation Overview

The TY96/TY97 VHF Radio must be mounted rigidly in the aircraft panel. The following installation procedure should be followed, remembering to allow adequate space for installation of cables and connectors.

- Select a position in the panel that is not too close to any high external heat source. (The radio is not a significant heat source itself and does not need to be kept away from other devices for this reason).
- Prepare the instrument panel to ensure the radio mounting tray can be secured using the mounting holes in the tray. The front edge of the mounting tray should sit flush with the instrument panel.
- It is advisable to complete the 25 way D-sub cable harness at this point before securing the mounting tray into the aircraft. The cable harness and antenna connector can then be secured to the removable mounting tray plate. Refer to section 5.4 for cable harness details and section 5.5 for fitting the antenna connector.
- Route the mounting tray plate and cable harness into position, avoiding sharp bends and placing the cables too near to the aircraft control cables.
- Attach the VHF antenna coax using a BNC connector.
- Clip the mounting tray plate into the mounting tray and secure with M2.5 pan head screws.

Note: The mounting tray plate clips into the mounting tray to aid assembly but must be secured using screws. The clips alone are not strong enough to retain the back plate when fitting the radio.

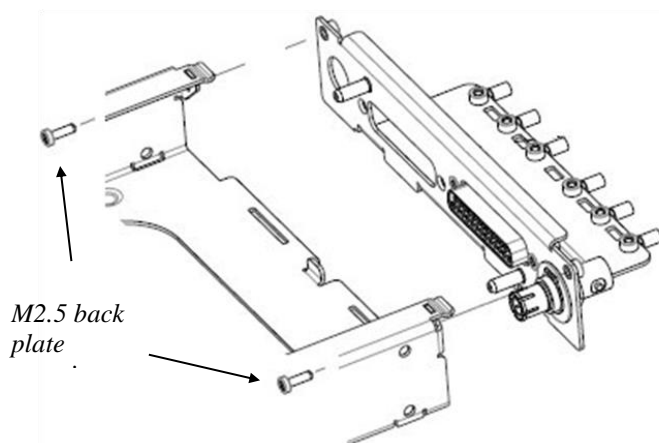

- Secure the mounting tray to the instrument panel via the six (6) mounting holes in the tray. It is important that the tray is supported at the rear with at least two mounting holes as well as the front four.
- Check that the VHF radio locking mechanism is correctly oriented by unscrewing the locking screw using a 3/32" Allen key.

- Slide the VHF radio into the secured mounting tray.
- Lock the VHF radio into the mounting tray using a 3/32" Allen key, taking care not to over tighten the locking screw.

5.3 Cooling Requirements

The VHF radio meets all applicable ETSO requirements without forced air-cooling. Reasonable air circulation should be provided.

Attention should be given to the incorporation of cooling provisions to limit the maximum operating temperature if the TY96 is installed in close proximity to other avionics. The reliability of equipment operating in close proximity in an avionics bay can be degraded if adequate cooling is not provided.

5.4 Electrical Connections

The TY96 has single 25 way D-type connector which is used for all the data and audio signals. A single coaxial BNC is used to connect the antenna.

Pin	Signal	Direction
1	Speaker Out	Output
2	Headphone 1 Left Out	Output
3	Headphone 1 Right Out	Output
4	Ground	-
5	Headphone 2 Left Out	Output
6	Headphone 2 Right Out	Output
7	Mono Audio Out	Output
8	Lighting Bus In	Input
9	Ground	-
10	Transmit Interlock In	Input
11	RS232 Out	Output
12	RS232 In	Input
13	Aircraft Power (DC)	-
14	Aux Audio	Input
15	Music Audio Left In	Input
16	Music Audio Right In	Input
17	Ground	-
18	Microphone 1	Input
19	Microphone 2	Input
20	Reserved	Input
21	Remote Flip-Flop	Input
22	Intercom Key	Input
23	PTT1	Input
24	PTT2	Input
25	Aircraft Power (DC)	-

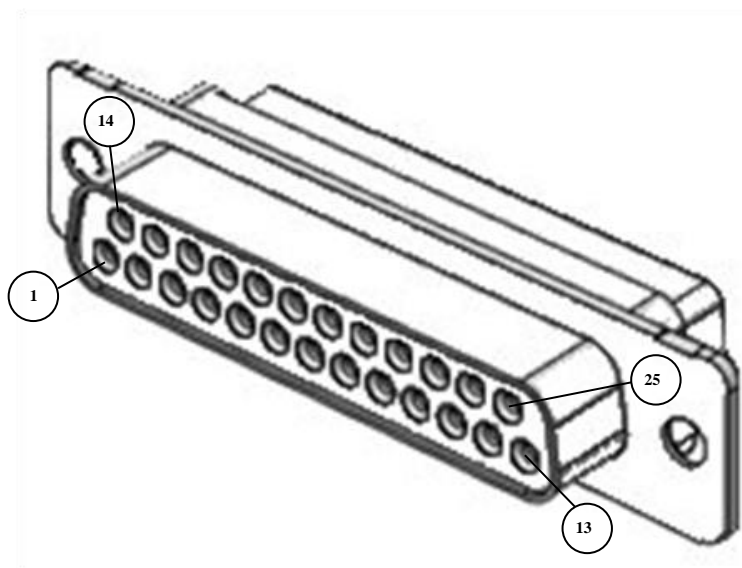
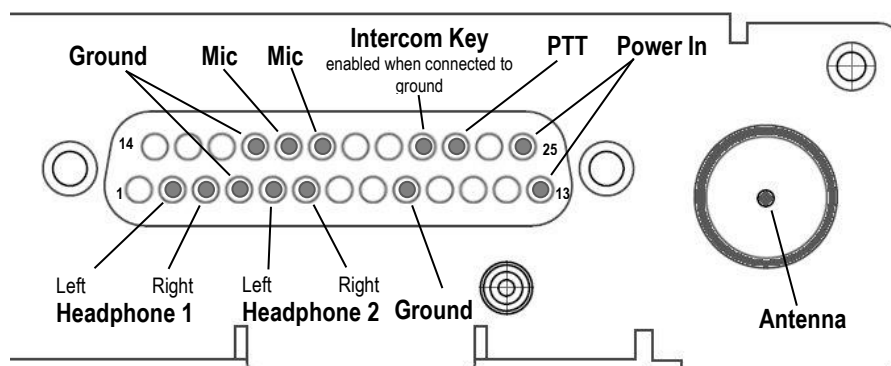

Figure 1: Mounting Tray 25 D-type Primary Connector

5.4.1 Orientation Diagram

To assist in connector orientation, the following example shows a typical set of connections. This diagram shows the expected connector positions when viewed from the radio side of the tray, looking into the tray from the front.



5.4.2 D Connector Crimp Terminals

The 25 way connector supplied with the TY96 installation kit are MIL standard versions of the popular sub miniature D type connector family, and use individual crimp terminals and a receptacle. The MIL specification for this family of connectors is MIL-C-24308. We supply crimp terminals because these are more reliable than soldered connections, and are easier to assemble in-situ in an aircraft, where soldering is impractical. They also allow individual wires to be removed and replaced in a receptacle without replacing the whole connector.

The socket contacts used in the connectors conform to MIL part number M39029/63-368, and are also suitable for wire gauges from 20 to 24 AWG.

These contacts are widely used in avionics installation, and there are many tools available on the market that will reliably crimp them to the wiring. Because the contacts are a MIL standard, there is also a MIL standard for the crimp tool, although other proprietary solutions are available.

The MIL reference for the basic style of hand tool is M22520/2-01. This style of tool can crimp many different contact types, and relies on interchangeable "positioners" to hold the actual contact in use. The MIL reference for the positioner that you need for the crimps we supply is M22520/2-08.

Any tool that complies with these references can be used to crimp these contacts. One of the most popular vendors of these small hand tools is Daniels Manufacturing Corporation (see www.dmctools.com). Their AFM8 hand tool complies with M22520/2-01, and their K13-1 positioner is M22520/2-08 compliant, so the combination will crimp the supplied connectors.

Once crimped, the contacts should be slotted into the rear of the connector shell. Push the contact in until the retaining tab clicks into place. Tug gently to confirm the contact is locked in place.

5.4.3 Power and Ground Wiring

The peak current consumption of the TY96 on transmit exceeds the current capability of a single pin on the connector. Both power inputs must be wired, and at least two ground returns must be wired. This is particularly important when the VHF radio is mounted on a non-conducting surface, such as a composite structure.

Use 20 AWG wire for the power connection wires.

5.4.4 Stereo Wiring Considerations

The TY96 uses stereo for the headphone connections. It is important to connect the left and right audio signals correctly to ensure the intercom and dual watch audio is correctly routed to the headphones. A typical general aviation headset will have the left channel on the tip and the right channel on the ring of the phones jack.

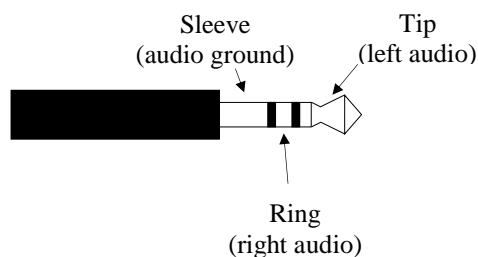

Intercom Audio

When using the stereo intercom, the audio output will appear more towards the side of the person who is speaking. For example, when the pilot is speaking, the co-pilot will hear this slightly more in their left ear than their right.

If the stereo wiring is incorrect then the audio will be routed to the wrong side of the headphones.

Dual Watch Audio

When using the dual watch function, the TY96 will route audio received on the primary channel to the centre of both headphones. Audio received on the secondary channel will be quieter and routed to the rear-right of the headphones.

5.4.5 Mono Wiring Considerations

The TY96 audio wiring can be connected to suit a mono installation. To do this, you must short the left and right signal wires together at the TY96 end of the loom. This will have the effect of placing all audio in the centre of the connected headphones.

This may be relevant when replacing a previous mono VHF radio where you wish to utilise the existing wiring and mono headset jacks.

5.4.6 Audio Wiring

All wires carrying audio signals should be wired using 22 AWG shielded cable to MIL-C-27500 or

equivalent. Mono audio signals should use 2 core shielded cable and stereo signals should use 3 core shielded cable. One core wire within each shielded cable should be connected to ground; the cable shield should not be used to carry the audio ground signals.

The cable shield should be connected to ground at the TY96 end only. Do not connect the shield at both ends of the cable to avoid a ground loop which can increase interference effects.

When terminating shielded cable it is recommended to cut away the cable insulation to expose the cable shield. At the end of the cable, strip the insulation and shield back at least 90mm. Trim the audio signal wires back to 30mm, keeping the signal ground wire at least 90mm in length.

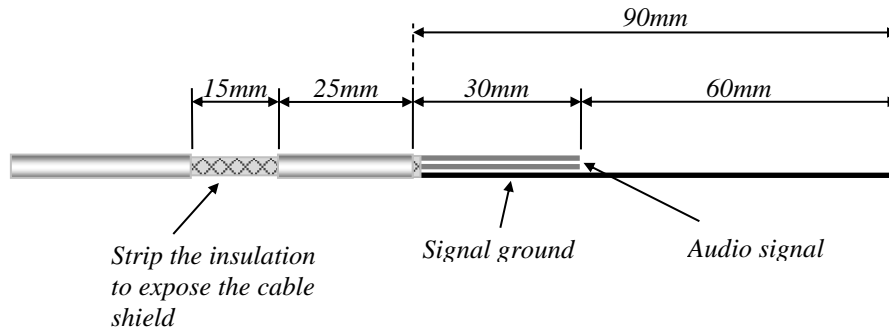

The audio signal wires can be terminated with D connector socket contacts that conform to MIL part number M39029/63-368.

Using a solder sleeve, attach some flat copper braid to the exposed shield and terminate with a crimp ring. Repeat for all shielded cable and connect the crimp ring terminals to the ground points on the mounting tray back plate.

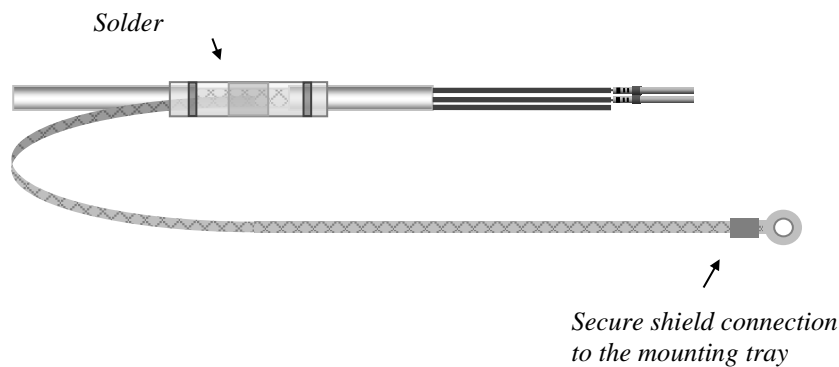

Connect the cable shields to the mounting tray back plate along with the signal ground connections. Secure the ring crimps to the back plate ground lugs using M2.5 screws and spring washers.

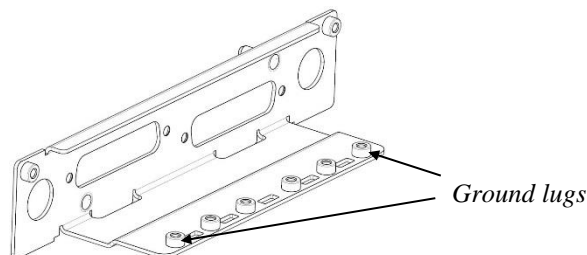

The signal ground wires from all the shielded cables should be grouped together and terminated with another ring crimp along with a ground fly lead that will be used to connect to a ground pin on the 25 way connector.

The ground fly lead wire size should be 20 AWG and terminated with another D connector socket contact.

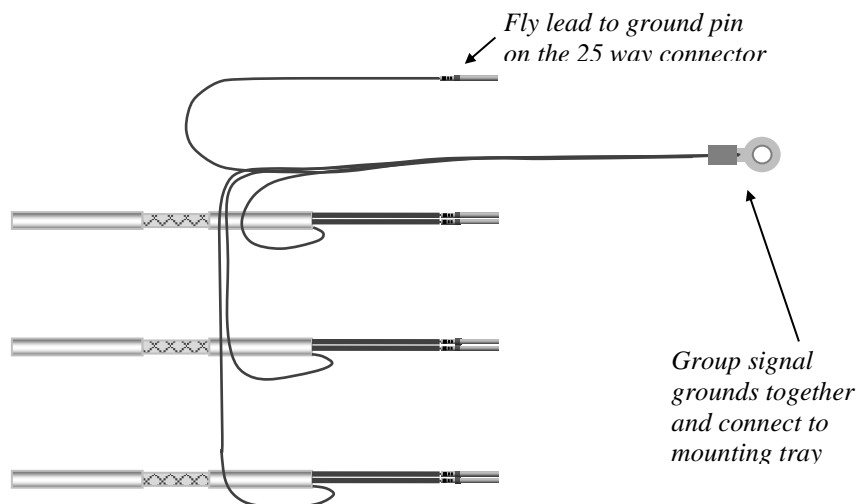

5.4.7 Example Wire Harness

Below is a typical example of the TY96 wire connections, shown without the D-Sub backshell.

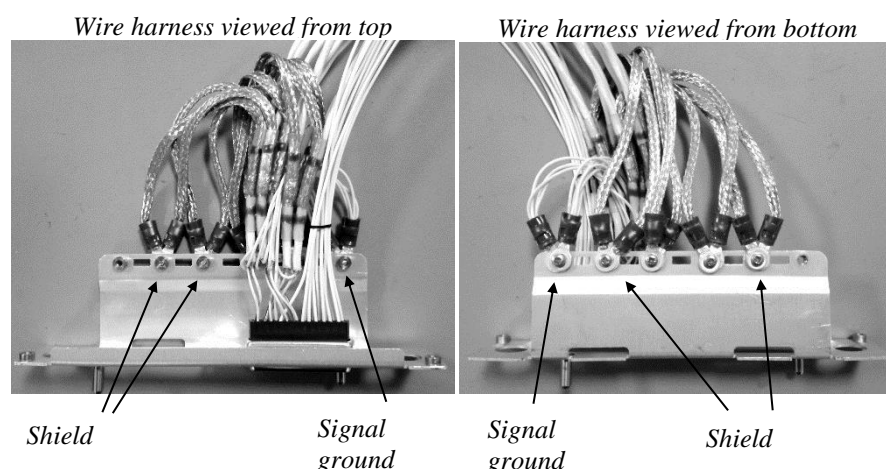

5.5 Antenna Installation

The VHF antenna should be installed according to the manufacturer's instructions.

The following considerations should be taken into account when siting the Antenna.

- The antenna should be well removed from any projections, the engine(s) and propeller(s). It should also be well removed from landing gear doors, access doors or others openings which will break the ground plane for the antenna.
- Avoid mounting the antenna within 2 feet of a GPS antenna, and as far as practical from any ELT antenna.
- If the simultaneous use of two radio units is required then each antenna should be as far apart as practicable for maximum isolation. We would recommend placing one antenna on top and one on the bottom of the airframe. The Transmit Interlock function should also be used in this

case (section 5.6.4).

- Where practical, plan the antenna location to keep the cable lengths as short as possible and avoid sharp bends in the cable to minimise the VSWR.

Electrical connection to the antenna should be protected to avoid loss of efficiency as a result of the presence of liquids or moisture. All antenna feeders shall be installed in such a way that a minimum of RF energy is radiated inside the aircraft.

5.5.1 Antenna Ground Plane

When a conventional aircraft monopole antenna is used it relies on a ground plane for correct behaviour. For ideal performance the ground plane should be as large as practical; in any case at least 1 metre square. In a metal skinned aircraft this is usually easy to accomplish, but is more difficult in a composite or fabric skinned aircraft. In these cases a metallic ground plane should be fabricated and fitted under the antenna.

The thickness of the material used to construct the ground plane is not critical, providing it is sufficiently conductive. A variety of proprietary mesh and grid solutions are available. Heavyweight cooking foil meets the technical requirements, but obviously needs to be properly supported.

5.5.2 Antenna Cable

Use a high quality 50 ohm coaxial cable, such as RG400 or RG142B.

When routing the cable, ensure that you:

- Route the cable away from sources of heat.
- Route the cable away from potential interference sources such as ignition wiring, 400Hz generators, fluorescent lighting and electric motors.
- Allow a minimum separation of 300mm (12 inches) from any ADF or transponder antenna cables.
- Keep the cable run as short as possible.
- Avoid routing the cable round tight bends.
- Avoid kinking the cable even temporarily during installation.
- Secure the cable so that it cannot interfere with other systems.
- The antenna cable should be terminated with BNC type male connector

5.5.3 BNC Connection

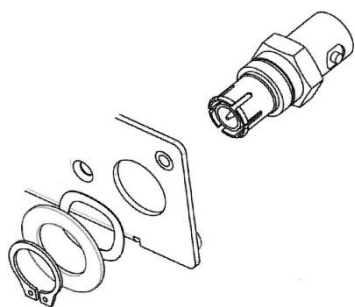

Feed the supplied blind mate BNC connector to the TY96 mounting tray back plate and attach the washer combination in the following order:

- Wave washer (p/n 00317-00).
- Plain washer (p/n 00241-00).

- Circlip washer (p/n 00242-00).

The Circlip washer should be fitted with a set of Circlip pliers.

5.6 Interface Details

5.6.1 Speaker Output

The speaker output can drive a 4 ohm or greater cabin speaker. The speaker should be rated at 4 watts or higher.

5.6.2 Headphone Outputs

The TY96 can drive two sets of headphones. The output is stereo and is intended for headsets of 150 to 600 ohm impedance.

The radio also works correctly when a mono headset is plugged into a stereo socket, or can be wired for mono headphones sockets.

5.6.3 Mono Audio Output

This output is used to drive a conventional 600 ohm audio panel input. Note that only the received radio transmission and sidetone will be output; music and aux audio will NOT be present.

5.6.4 Transmit Interlock

When two VHF radios are mounted in an aircraft the transmit interlock input of one can be connected to the transmit PTT key of the other radio. When the other radio transmitter is keyed, the squelch threshold of this radio is increased to minimise break-through between one radio and the other.

Note: To improve the performance when using two radios, the antennas should be as far apart as practical – for example on the top and bottom of the fuselage.

5.6.5 Lighting Bus Input

The TY96 will adjust the brightness of the front panel switch lighting according to the voltage on the lighting bus input. The lighting bus voltage is automatically adapted to the aircraft bus voltage.

If no lighting bus input is detected, the radio will automatically control the front panel lighting based on the ambient light sensor.

5.6.6 PTT1/2 Key Input

Two Push to Talk (PTT) inputs are provided, which correspond to the two microphone inputs. Only the corresponding microphone input is routed to the transmitter when the key switch is pressed.

The PTT1 input has priority over the PTT2 input – if the PTT1 switch is closed when the PTT2 switch is closed, the input from Microphone 1 is routed to the transmitter.

The inputs are active low, and will be asserted when the voltage to ground is pulled below approximately 4 volts. The input should be connected to a momentary switch on the yoke or on the microphone.

For retrofit installations where a single PTT input is shared for both microphone inputs, Single PTT mode can be enabled. See section 6.2.14 for more details.

5.6.7 Intercom Key Input

The intercom key switch input allows the intercom function to be selected using a remote switch, or permanently enabled by grounding the pin inside the connector. The input is active low, and will be asserted when the voltage to ground is pulled below approximately 4 volts.

If this pin is tied low, the intercom function depends on the vox operated squelch.

Note: It is possible to combine both the key switch and the vox activation, or to use only one.

To use only the switch, wire the switch to the intercom key input and select the vox squelch to the lowest setting during configuration. To use only the vox, wire the intercom key input to ground, and configure the squelch accordingly.

5.6.8 Auxiliary Audio Input

This input is continually routed to the headphone and cabin speaker outputs. It is intended for annunciators and identification tones.

5.6.9 Music Audio Input

This is a stereo input which is routed to the both headphone outputs and should be used for connecting an MP3 player or similar device. The music input volume is adjustable and the music mute options can be configured within the setup menu to allow the radio reception or transmission audio to take priority.

5.6.10 Microphone Input

Microphone connections should be made using shielded twisted pair cables.

The two microphone inputs are identical, and have a nominal sensitivity of 1Vrms to 5Vrms into a 600 ohm load. A 12Vdc bias voltage is supplied by the radio to the microphone inputs to support a preamplifier in the microphone.

The microphone gains can be adjusted within the setup menu.

5.6.11 RS232 Input/Output

The RS232 input allows certain GPS receivers to preload the standby and active frequencies. The radio understands the Apollo SL40 protocol (\$PMRRC) based on NMEA, at a speed of 9600 bps, and responds to message types 1, 4, 5 and 6.

5.6.12 Remote Flip-Flop

This input is used to allow remote activation of the frequency change, and is typically used in a helicopter. The input is active low, and will be asserted when the voltage to ground is pulled below approximately 4 volts.

5.6.13 Power Input

The TY96 power supply can be 11-33 volts DC; no voltage adjustment is required. Use a 5 Amp circuit breaker for power supply protection to the TY96. The TY97 requires 22-33 volts DC; again use a 5 amp circuit breaker.

The peak current consumption on transmit exceeds the current capability of a single pin on the connector. Both power inputs must be wired, and at least two ground returns must be wired. Use 20 AWG wire for the power connection wires.

5.6.14 Ground Returns

There are only 3 ground pins on the 25 way connector, at pins 4, 9 and 17. Two of these ground pins should be used for the power input leaving the other ground pin for the audio grounds. Audio grounds should be connected together with a fly lead connected to the remaining ground pin. Refer section 5.4 for further wiring considerations.

6. Installation Setup and Test

6.1 Initial Power On

The TY96 will display a splash screen when the radio is first switched on. The splash screen shows the software versions currently loaded and what model of radio is connected.

6.2 Configuration Items

There are a small number of installation parameters that can be adjusted. Those that are expected to be operated in flight are accessed by pressing and holding the MON button for approximately 2 seconds. Those that are infrequently accessed only appear when a second step is accomplished by pressing and holding the MEM button for 2 seconds after the settings screen is displayed.

The individual setup items are selected using the large tuning knob, and adjusted using the small tuning knob. Pressing MON again will exit from the setup mode.

The base set of parameters are:

- Intercom Volume
- Intercom Squelch
- Music Volume
- Music Muting

The items accessed on the second level of menu are:

- Frequency Step Size – not available on TY96A/97A
- Auxiliary Input Volume
- Auxiliary Input Muting
- Sidetone Volume
- Receiver Squelch Offset
- Microphone gain adjustment
- Display Dim and Brightness settings
- Single PTT configuration
- Audio Test Tones

6.2.1 Intercom Volume

This setting controls the volume of the built-in intercom.

6.2.2 Intercom Squelch

The intercom includes a voice activated squelch control to limit the background noise heard over the intercom. Increasing the squelch level requires a louder microphone input to turn on the intercom.

6.2.3 Music Volume

This setting controls the volume of the stereo music input. The listening level is controlled by this setting, and also by the volume controls on the music source. Set the music volume so that a reasonable level is achieved with the source set to a typical playback setting.

6.2.4 Music Muting

Turn this feature ON if the music should mute during radio reception. Turning this feature off leaves the music playing during reception. The music always mutes when the radio is transmitting.

6.2.5 Frequency Step Size

The TY96/TY97 is capable of operating in both an 8.33 kHz and 25 kHz environment. If 8.33 kHz operation is not required, the 8.33 kHz channels can be disabled to simplify the tuning operation.

Note: 8.33 kHz operation is required in some European airspace.

The TY96A/TY97A are only capable of operating in a 25 KHz environment.

6.2.6 Auxiliary Input Volume

The auxiliary input is a low-fidelity monophonic input intended for nav radio ident inputs and simple annunciators. This setting controls the relative volume of the auxiliary audio input.

6.2.7 Auxiliary Input Muting

This allows the auxiliary input to be muted when the radio is receiving or transmitting speech. Turn this feature ON if the auxiliary input is being used for non-essential services, like an MP3 player. Turn this feature OFF if the auxiliary input is being used for essential services like annunciators or traffic alerts.

6.2.8 Sidetone Volume

The audio sidetone is the transmitted audio signal; this setting controls the level of the sidetone in the headphones.

6.2.9 Receiver Squelch Offset

The receiver has a factory set nominal squelch point of approximately -95 dBm which should be appropriate for most installations. In some aircraft with noisy electrical environments, such as vintage or experimental aircraft, the factory setting may lead to nuisance squelch breaking.

The receiver squelch offset allows the installer to moderately increase the squelch set point.

6.2.10 Audio Test Tones

The audio test tones provide a simple way of testing that the installation is correctly wired. The radio has two stereo headphone outputs, a mono line output, and a cabin speaker output. The audio test tone generator sends a sequence of tones to each of those outputs in turn.

Use the small right hand knob to scroll through the output choices, and check that each output in turn is correct. The stereo music and intercom functions will appear in the wrong positions if the wiring is incorrect.

During the test the volume knob controls the active outputs.

6.2.11 Microphone gain adjustment

The factory set microphone adjustment provides a nominal sensitivity of 100 mV RMS which is compatible with most conventional aviation headset microphones. Automatic gain control takes care of variations in speaking voice and variation between different microphones. Microphone adjustment is therefore only required to correct for alternative installation choices. If the installation uses unusually high output microphones, or an audio panel with built-in amplification, the radio input can be overloaded and cause distortion on the transmitted audio. If the microphone output is too low, the transmitted modulation will be low, and may be unreadable. Each microphone input can be adjusted separately.

The microphone gain is adjusted in steps of 1 dB. The left end stop on the range corresponds to a nominal sensitivity of 200 mV; the right end stop corresponds to a nominal sensitivity of 6 mV. The factory original setting is 6 steps from the left of the range.

6.2.12 LCD Dim Point

The LCD backlight illumination is controlled automatically by the ambient light sensor. Depending on

the amount of light spill in the cockpit, and the brightness of other adjacent avionics displays, it may be necessary to adjust the darkest setting of the backlight to best match other equipment and to improve the cockpit appearance at night.

Note – it is only practical to do this in pitch darkness, since that is the in-flight environment that you are trying to reproduce. If you are working in a hangar with any other lighting it may be better to leave the setting in the mid-range.

6.2.13 LCD Brightness Curve

The actual maximum brightness of the LCD cannot be increased with this control. What it controls is the rate at which the lighting increases in brightness as the ambient light increases. This allows the brightness to be matched to other avionics displays during light level changes as far as possible.

6.2.14 Single PTT Mode

In the factory standard configuration pressing PTT1 sends only Mic 1 to the transmitter; PTT2 sends only Mic 2. For a retrofit installation, for example when replacing an SL40 radio, a single PTT is shared between the two microphones. Enabling Single PTT mode means that whenever PTT1 is pressed both Mic 1 and Mic 2 audio is sent to the transmitter.

7. Post Installation Checks

Post installation checks should be carried out in accordance with your certification requirements. These checks should include:

- Receiver operation. Tune a local station and check that the reception is clear and understandable.
- Transmitter operation and microphone gain adjustment. Contact a local station and check that they are receiving you clearly.
- Interference check. Check the radio with other avionics and electrical equipment on the aircraft operating. Check at low, mid and high radio frequencies. There should be no significant interference on reception, and when the TY96/TY97 transmits there should be no adverse effect on any other equipment.
- Sidetone adjustment. During the transmit checks, verify the sidetone level is set appropriately.
- Intercom adjustment. If the intercom function is being used, set the listening level and squelch appropriately. Note that the squelch is best adjusted in the normal ambient noise environment, for example with the engine(s) running and developing power.

8. Normal Operation

8.1 Overview

On the front panel is a monochrome LCD display flanked by a rotary volume knob (OFF, and Squelch function) and a dual concentric tuning knob used for frequency entry.



8.2 Display

The display shows the active and standby frequencies for the radio, and has icons to indicate the operating modes. An internal database automatically fills in the station identifier for the tuned frequency if it is one of the stored values.

The primary frequency is on the left and the standby frequency is on the right hand half of the screen. The **TX** icon shows that the radio is transmitting. An **RX** icon shows that the frequency is active and the audio will be heard through the headphone and speaker outputs. The standby frequency will only be received during the MONITOR function which is indicated by a **M** icon when active.

The top right hand corner indicates what frequency step size is selected – this determines the resolution of the small tuning knob, and NOT the radio performance, which is determined by the actual channel tuned.

The display brightness automatically dims based on ambient light.

8.3 On/Off Volume Knob

The left hand knob controls the power to the VHF radio, adjusts the audio volume, and controls the squelch. Turning this knob clockwise will switch on the radio and then increase the volume. Turning anticlockwise will reduce the volume and eventually will click off.

Pressing this knob toggles the automatic squelch on and off, which can be used to listen for faint stations and as a simple audio test.

8.4 Tuning Knobs

The right hand knobs are used to tune the radio. The large knob adjusts the MHz portion of the standby frequency, and the smaller knob adjusts the kHz portion of the standby frequency.

On the TY96/97 pressing the end of the small knob changes the channel spacing that the small knob operates through. If the radio is configured for 8.33 kHz operation, the steps toggle between 8.33 kHz channels and 25 kHz channels. If the radio is configured only for 25 kHz operation, the steps toggle between 25 kHz and 50 kHz channels. Changing the step size does not change the behaviour of the radio, only the tuning knob step size – it helps to quickly tune a frequency.

On the TY96A/97A pressing the end of the small knob will always change the channel spacing between 25 KHz and 50 kHz channels.

8.5 Flip-flop Button

The Flip-flop button swaps the frequency in the standby display at the right of the screen, into the active position, and moves the active frequency to the standby position.

8.6 MON Button

The TY96/TY97 includes a dual-frequency listen feature; pressing the MON button toggles this feature on and off.

When the monitor is active, a **+2** icon appears next to the standby frequency, and the radio will scan between the active and standby frequencies listening for transmissions.

This is useful in an aircraft with only a single radio, since it allows you, for example, to copy the ATIS whilst maintaining a listening watch on the ATC frequency.

8.7 MEM Button

Pressing the MEM button replaces the standby frequency display with the database screen. There are three databases in the radio – a pilot stored list of frequencies, a list of the recently used frequencies, and a list of frequencies transferred from an attached GPS database.

In memory mode turning the large tuning knob moves the cursor while turning the small tuning knob changes the highlighted item.

8.8 PLAY Button

The VHF radio includes a digital audio recorder. Pressing the PLAY button will automatically replay the previous transmission received from ATC. During playback the **PB** icon will be displayed on the screen.

If a new transmission is received during playback, the playback is cancelled and the live transmission will be heard instead.

8.9 EMER Button

The EMER button gives quick access to the standard emergency frequency of 121.5 MHz. As well as selecting 121.5 MHz, pressing the EMER button also mutes the music input and the auxiliary audio input, and if the volume is set to a low level it turns it up.

8.10 Saving and Loading the Frequency Database

The frequency database entries you have made can be saved to a USB memory stick, or you can load a database from a USB stick. To load or save to USB, you need to put the USB memory stick into the radio before you switch on. When the radio detects the USB device it will offer to save or load your database. If there are data entries already on the radio you will be offered the choice to replace the whole database, or add entries from the USB stick. Similarly if there is already a database on the USB stick you can either overwrite it or add the radio data to the existing file. See section 14 for more details on the USB operation.

To return to normal radio operation remove the USB device and switch the radio off and back on again. In normal radio operation the USB port is powered off.

8.11 General Low Temperature Operation

The TY96/TY97 is certified to operate correctly down to -20°C, but at low temperatures the controller display may be impaired. On a cold day you may need to wait for the cockpit to warm up to ensure normal operation.

8.12 Warning Messages

If the VHF radio detects a problem, the screen will indicate WARNING and a brief statement of the problem. Depending on the nature of the problem, your VHF radio may not be working properly. Note the message on the screen and pass that information to your avionics maintenance organisation.

Warning messages will automatically clear if the problem is corrected. If a warning persists, it can be manually cleared by pressing the flip-flop button twice.

8.13 Fault Annunciation

If the VHF radio detects a catastrophic internal failure, the screen will indicate FAULT and a brief statement of the problem. The controller will not respond to button or knob inputs, but the radio may still be working on the last settings prior to the fault indication.

Some FAULT indications can be recovered by switching the VHF radio off and back on again, although in all cases a FAULT code implies that there is a fault with the VHF radio or the installation. Note the FAULT message shown on the screen and pass that information to your avionics maintenance organisation.

9. Continued Airworthiness

Other than for periodic functional checks required by the regulations, the TY96/TY97 VHF radio has been designed and manufactured to allow “on condition maintenance”. This means that there are no periodic service requirements necessary to maintain continued airworthiness, and no maintenance is required until the equipment does not properly perform its intended function. When service is required, a complete performance test should be accomplished following any repair action. Repairs should only be carried out in accordance with Trig Avionics Limited service procedures.

9.1 *Cleaning the Front Panel*

The plastic body and switches should be cleaned with a soft cotton cloth moistened with clean water. The LCD screen should be lightly cleaned with a lint free cloth taking care not to scratch the surface.

10. Limited Warranty

Trig Avionics Limited warrants our products to be free from defects in materials and workmanship for a period of two (2) years from the date of installation by an authorised dealer.

This warranty covers repair and/or replacement at our option, of any parts found to be defective, provided such defects in our opinion are due to faulty material or workmanship and are not caused by tampering, abuse, or normal wear.

All warranties are F.O.B.

Trig Avionics Limited
Heriot Watt Research Park
Riccarton, Edinburgh, EH14 4AP

Trig Avionics will not accept or pay for any charges for warranty work performed outside our factory without prior written consent.

This warranty applies only to products in normal use. It does not apply to units or circuit boards defective due to improper installation, physical damage, tampering, lightning or other electrical discharge, units with altered serial numbers, or units repaired by unauthorised persons or in violation of Trig Avionics Limited service procedures.

Trig Avionics Limited assumes no responsibility for any consequential losses of any nature with respect to any products or services sold, rendered, or delivered.

11. Environmental Qualification Forms

Nomenclature:	TY96 VHF Radio	
Part Number:	01226-00-xx	
ETSO:	2C169a, 2C128	
Manufacturer:	Trig Avionics Limited	
Address:	Heriot Watt Research Park, Edinburgh, Scotland, EH14 4AP	
Conditions	DO-160G	Description of Conducted Tests
Temperature and Altitude	4.0	Equipment tested to Categories: A4, C4
Low temperature ground survival	4.5.1	-55°C
Low temperature operating	4.5.2	-20°C
High temperature operating	4.5.4	+55°C
High temperature short-time operating	4.5.3	+70°C
High temperature ground survival	4.5.3	+85°C
Loss of Cooling	4.5.5	Cooling air not required (+70°C operating without cooling air)
Altitude	4.6.1	55,000 feet
Decompression	4.6.2	8,000 to 55,000 feet in 15 seconds
Overpressure	4.6.3	-15000 feet
Temperature Variation	5.0	Equipment tested to Category C
Humidity	6.0	Equipment tested to Category A
Operational Shocks	7.2	Equipment tested to Category B
Crash Safety	7.3	Equipment tested to Category B
Vibration	8.0	Aircraft zone 2; type 3, 4, 5 to category S level M; type 1 (Helicopters) to category U level G
Explosion	9.0	Equipment identified as Category X – no test required
Waterproofness	10.0	Equipment identified as Category X – no test required
Fluids Susceptibility	11.0	Equipment identified as Category X – no test required
Sand and Dust	12.0	Equipment identified as Category X – no test required
Fungus	13.0	Equipment identified as Category X – no test required
Salt Spray	14.0	Equipment identified as Category X – no test required
Magnetic Effect	15.0	Equipment tested to Category Z
Power Input	16.0	Equipment tested to Category BX
Voltage Spike	17.0	Equipment tested to Category B
Audio frequency conducted susceptibility	18.0	Equipment tested to Category B
Induced signal susceptibility	19.0	Equipment tested to Category AC
Radio frequency susceptibility	20.0	Equipment tested to Category TT
Radio frequency emission	21.0	Equipment tested to Category B
Lightning induced transient susceptibility	22.0	Equipment tested to Category B2H2L2
Lightning direct effects	23.0	Equipment identified as Category X – no test required
Icing	24.0	Equipment identified as Category X – no test required
Electrostatic Discharge	25.0	Equipment tested to Category A
Fire, Flammability	26.0	Equipment identified as Category C

Nomenclature:	TY96A VHF Radio	
Part Number:	01787-00-xx	
ETSO:	2C169a, 2C128	
Manufacturer:	Trig Avionics Limited	
Address:	Heriot Watt Research Park, Edinburgh, Scotland, EH14 4AP	
Conditions	DO-160G	Description of Conducted Tests
Temperature and Altitude	4.0	Equipment tested to Categories: A4, C4
Low temperature ground survival	4.5.1	-55°C
Low temperature operating	4.5.2	-20°C
High temperature operating	4.5.4	+55°C
High temperature short-time operating	4.5.3	+70°C
High temperature ground survival	4.5.3	+85°C
Loss of Cooling	4.5.5	Cooling air not required (+70°C operating without cooling air)
Altitude	4.6.1	55,000 feet
Decompression	4.6.2	8,000 to 55,000 feet in 15 seconds
Overpressure	4.6.3	-15000 feet
Temperature Variation	5.0	Equipment tested to Category C
Humidity	6.0	Equipment tested to Category A
Operational Shocks	7.2	Equipment tested to Category B
Crash Safety	7.3	Equipment tested to Category B
Vibration	8.0	Aircraft zone 2; type 3, 4, 5 to category S level M; type 1 (Helicopters) to category U level G
Explosion	9.0	Equipment identified as Category X – no test required
Waterproofness	10.0	Equipment identified as Category X – no test required
Fluids Susceptibility	11.0	Equipment identified as Category X – no test required
Sand and Dust	12.0	Equipment identified as Category X – no test required
Fungus	13.0	Equipment identified as Category X – no test required
Salt Spray	14.0	Equipment identified as Category X – no test required
Magnetic Effect	15.0	Equipment tested to Category Z
Power Input	16.0	Equipment tested to Category BX
Voltage Spike	17.0	Equipment tested to Category B
Audio frequency conducted susceptibility	18.0	Equipment tested to Category B
Induced signal susceptibility	19.0	Equipment tested to Category AC
Radio frequency susceptibility	20.0	Equipment tested to Category TT
Radio frequency emission	21.0	Equipment tested to Category B
Lightning induced transient susceptibility	22.0	Equipment tested to Category B2H2L2
Lightning direct effects	23.0	Equipment identified as Category X – no test required
Icing	24.0	Equipment identified as Category X – no test required
Electrostatic Discharge	25.0	Equipment tested to Category A
Fire, Flammability	26.0	Equipment identified as Category C

Nomenclature:	TY97 VHF Radio	
Part Number:	01228-00-xx	
ETSO:	2C169a, 2C128	
Manufacturer:	Trig Avionics Limited	
Address:	Heriot Watt Research Park, Edinburgh, Scotland, EH14 4AP	
Conditions	DO-160G	Description of Conducted Tests
Temperature and Altitude	4.0	Equipment tested to Categories: A4, C4
Low temperature ground survival	4.5.1	-55°C
Low temperature operating	4.5.2	-20°C
High temperature operating	4.5.4	+55°C
High temperature short-time operating	4.5.3	+70°C
High temperature ground survival	4.5.3	+85°C
Loss of Cooling	4.5.5	Cooling air not required (+70°C operating without cooling air)
Altitude	4.6.1	55,000 feet
Decompression	4.6.2	8,000 to 55,000 feet in 15 seconds
Overpressure	4.6.3	-15000 feet
Temperature Variation	5.0	Equipment tested to Category C
Humidity	6.0	Equipment tested to Category A
Operational Shocks	7.2	Equipment tested to Category B
Crash Safety	7.3	Equipment tested to Category B
Vibration	8.0	Aircraft zone 2; type 3, 4, 5 to category S level M; type 1 (Helicopters) to category U level G
Explosion	9.0	Equipment identified as Category X – no test required
Waterproofness	10.0	Equipment identified as Category X – no test required
Fluids Susceptibility	11.0	Equipment identified as Category X – no test required
Sand and Dust	12.0	Equipment identified as Category X – no test required
Fungus	13.0	Equipment identified as Category X – no test required
Salt Spray	14.0	Equipment identified as Category X – no test required
Magnetic Effect	15.0	Equipment tested to Category Z
Power Input	16.0	Equipment tested to Category BX
Voltage Spike	17.0	Equipment tested to Category B
Audio frequency conducted susceptibility	18.0	Equipment tested to Category B
Induced signal susceptibility	19.0	Equipment tested to Category AC
Radio frequency susceptibility	20.0	Equipment tested to Category TT
Radio frequency emission	21.0	Equipment tested to Category B
Lightning induced transient susceptibility	22.0	Equipment tested to Category B2H2L2
Lightning direct effects	23.0	Equipment identified as Category X – no test required
Icing	24.0	Equipment identified as Category X – no test required
Electrostatic Discharge	25.0	Equipment tested to Category A
Fire, Flammability	26.0	Equipment identified as Category C

Nomenclature:	TY97A VHF Radio	
Part Number:	01789-00-xx	
ETSO:	2C169a, 2C128	
Manufacturer:	Trig Avionics Limited	
Address:	Heriot Watt Research Park, Edinburgh, Scotland, EH14 4AP	
Conditions	DO-160G	Description of Conducted Tests
Temperature and Altitude	4.0	Equipment tested to Categories: A4, C4
Low temperature ground survival	4.5.1	-55°C
Low temperature operating	4.5.2	-20°C
High temperature operating	4.5.4	+55°C
High temperature short-time operating	4.5.3	+70°C
High temperature ground survival	4.5.3	+85°C
Loss of Cooling	4.5.5	Cooling air not required (+70°C operating without cooling air)
Altitude	4.6.1	55,000 feet
Decompression	4.6.2	8,000 to 55,000 feet in 15 seconds
Overpressure	4.6.3	-15000 feet
Temperature Variation	5.0	Equipment tested to Category C
Humidity	6.0	Equipment tested to Category A
Operational Shocks	7.2	Equipment tested to Category B
Crash Safety	7.3	Equipment tested to Category B
Vibration	8.0	Aircraft zone 2; type 3, 4, 5 to category S level M; type 1 (Helicopters) to category U level G
Explosion	9.0	Equipment identified as Category X – no test required
Waterproofness	10.0	Equipment identified as Category X – no test required
Fluids Susceptibility	11.0	Equipment identified as Category X – no test required
Sand and Dust	12.0	Equipment identified as Category X – no test required
Fungus	13.0	Equipment identified as Category X – no test required
Salt Spray	14.0	Equipment identified as Category X – no test required
Magnetic Effect	15.0	Equipment tested to Category Z
Power Input	16.0	Equipment tested to Category BX
Voltage Spike	17.0	Equipment tested to Category B
Audio frequency conducted susceptibility	18.0	Equipment tested to Category B
Induced signal susceptibility	19.0	Equipment tested to Category AC
Radio frequency susceptibility	20.0	Equipment tested to Category TT
Radio frequency emission	21.0	Equipment tested to Category B
Lightning induced transient susceptibility	22.0	Equipment tested to Category B2H2L2
Lightning direct effects	23.0	Equipment identified as Category X – no test required
Icing	24.0	Equipment identified as Category X – no test required
Electrostatic Discharge	25.0	Equipment tested to Category A
Fire, Flammability	26.0	Equipment identified as Category C

12. Installation Drawings

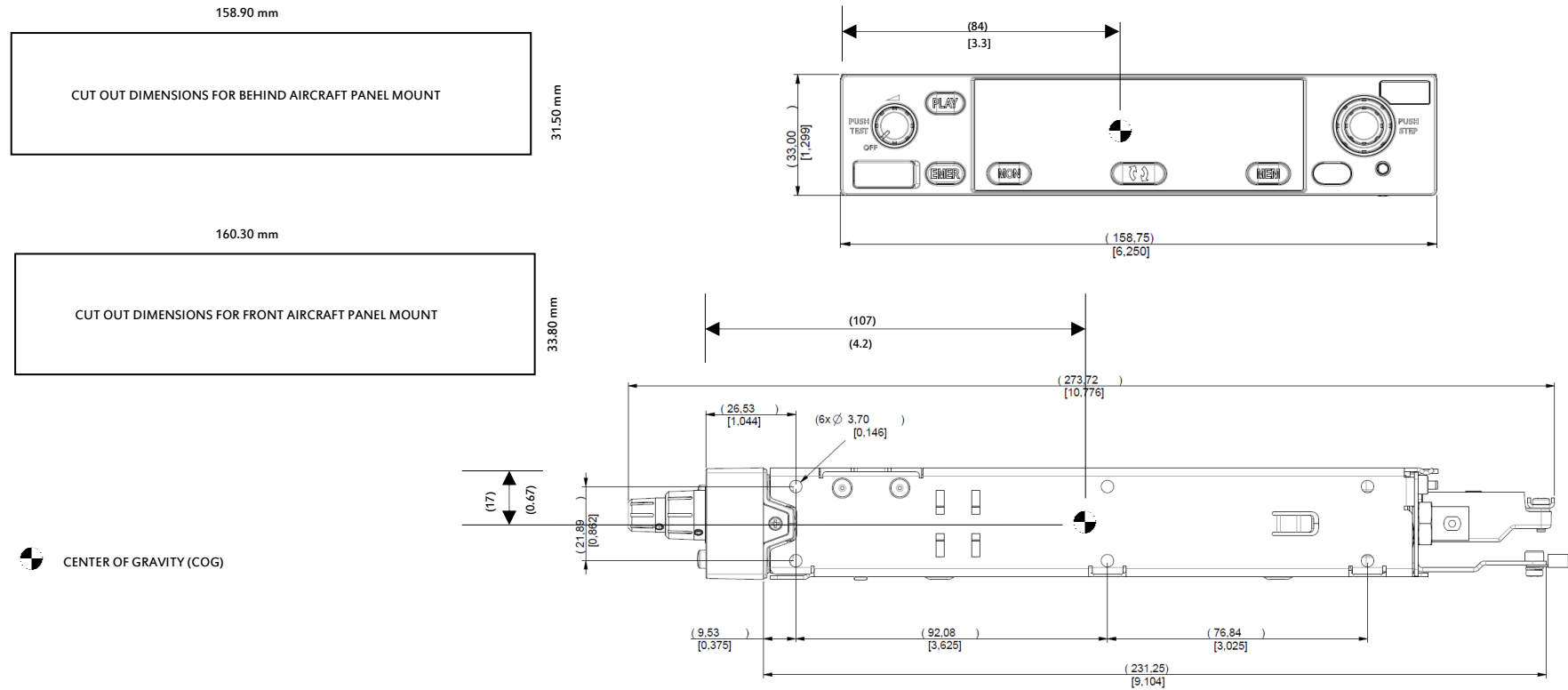

Dimensions in (--) are millimetres, dimensions in [--] are inches.

ITEM	DESCRIPTION	QTY
1	TY96 VHF Radio	1
2	TY96 Mounting Tray	1
3	TY96 Mounting Tray Back Plate	1
4	Screw M2.5 x 8mm, pan pozidrive	2

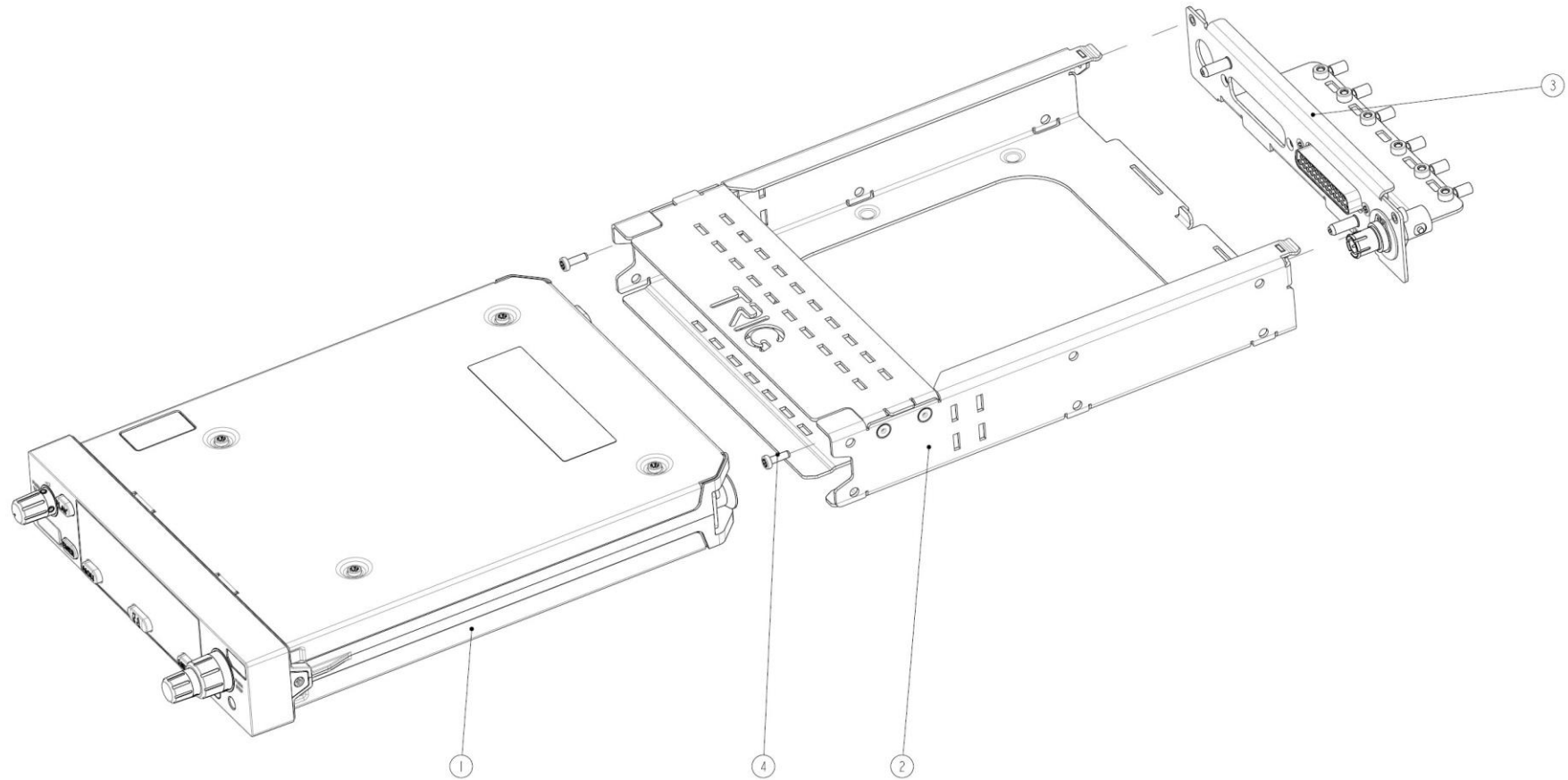

13. Wiring Diagrams

Diagram 1: System Interface.....34

Diagram 2: Typical standalone interconnect (no audio panel).....35

Diagram 3: Audio panel interconnect36

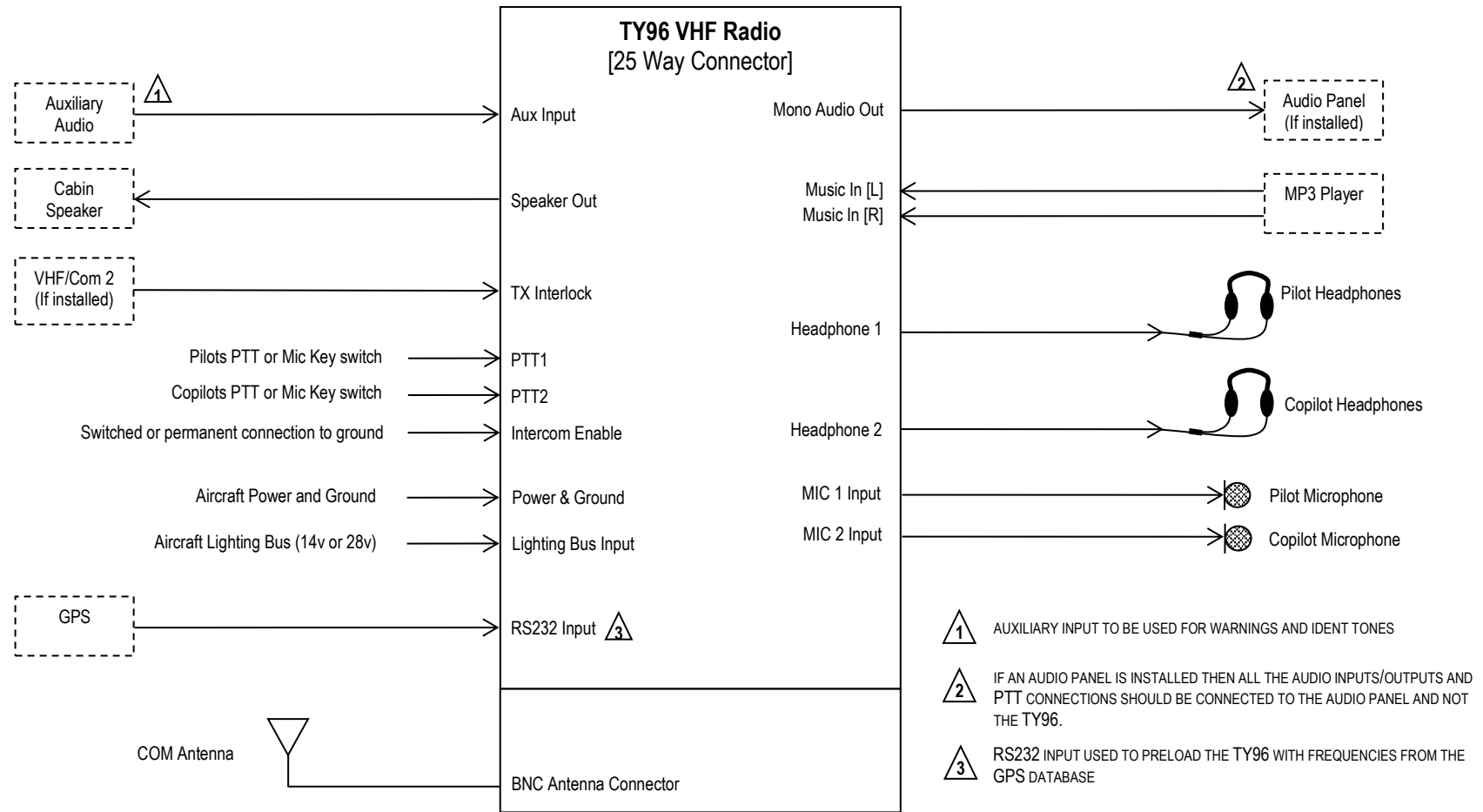
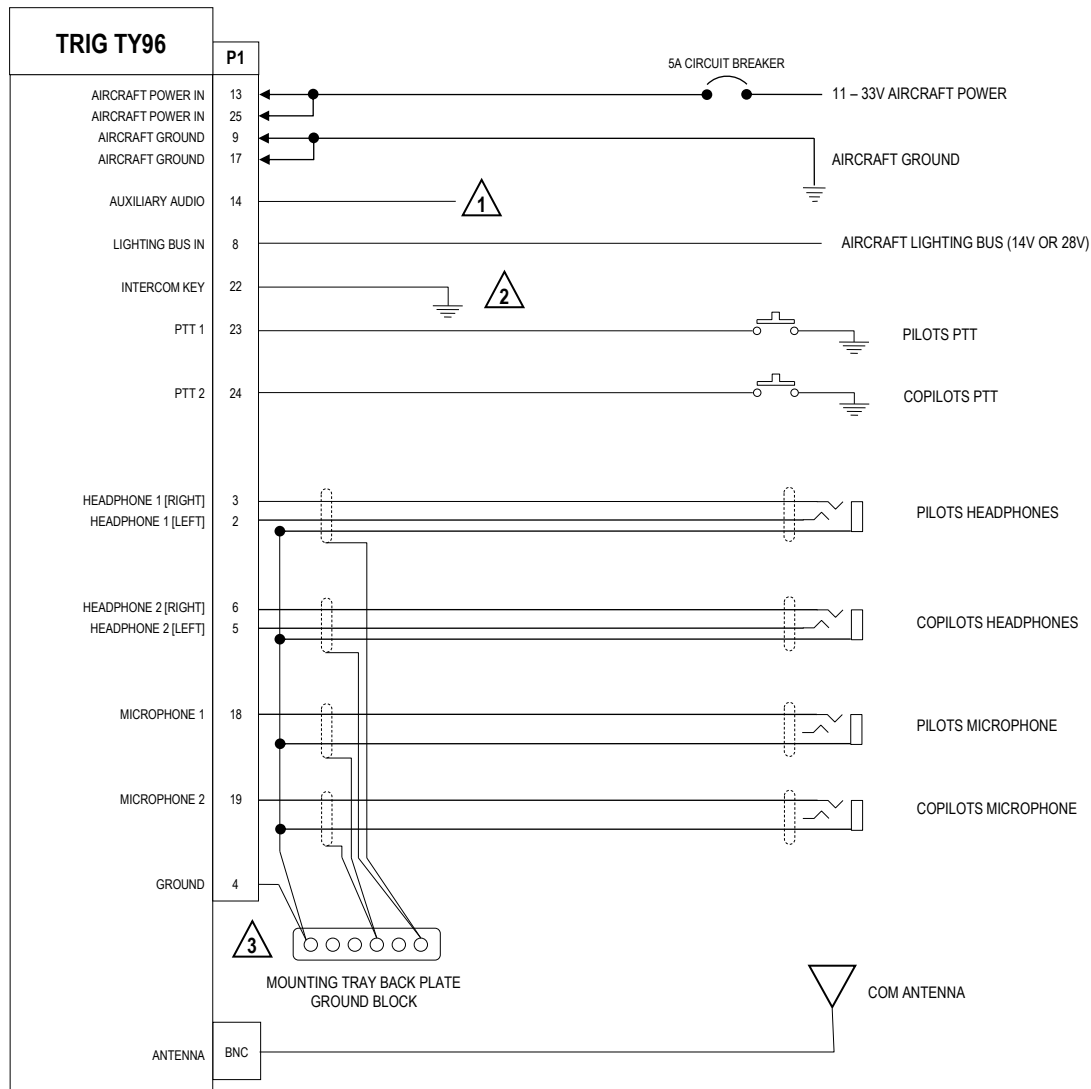

Diagram 1: System Interface



NOTES

1. POWER AND GROUND WIRES SHOULD ALL BE 20 AWG
2. ALL OTHER WIRES SHOULD BE 20 - 24 AWG UNLESS STATED OTHERWISE

1 AUXILIARY INPUT TO BE USED FOR WARNINGS AND IDENT TONES

2 THE TY96 INTERCOM IS ENABLED WHEN THIS PIN IS CONNECTED TO GROUND. THE GROUND SIGNAL CAN BE SWITCHED IF REQUIRED TO CREATE AN INTERCOM PTT. TO DISABLE THE INTERCOM LEAVE THIS PIN FLOATING.

3 ALL AUDIO GROUNDS SHOULD BE CONNECTED TO THE ONE OF THE GROUND LUGS ON THE MOUNTING TRAY BACK PLATE WITH A WIRE CONNECTING TO PIN 4 ON THE SAME LUG. ALL OTHER GROUND LUGS TO BE USED FOR THE SHIELD CONNECTIONS.

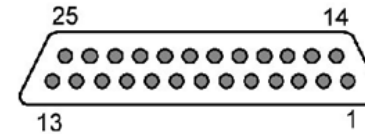

The diagram above shows the connector orientation as viewed from the wiring side (TY96 end)

Diagram 2: Typical standalone interconnect (no audio panel)

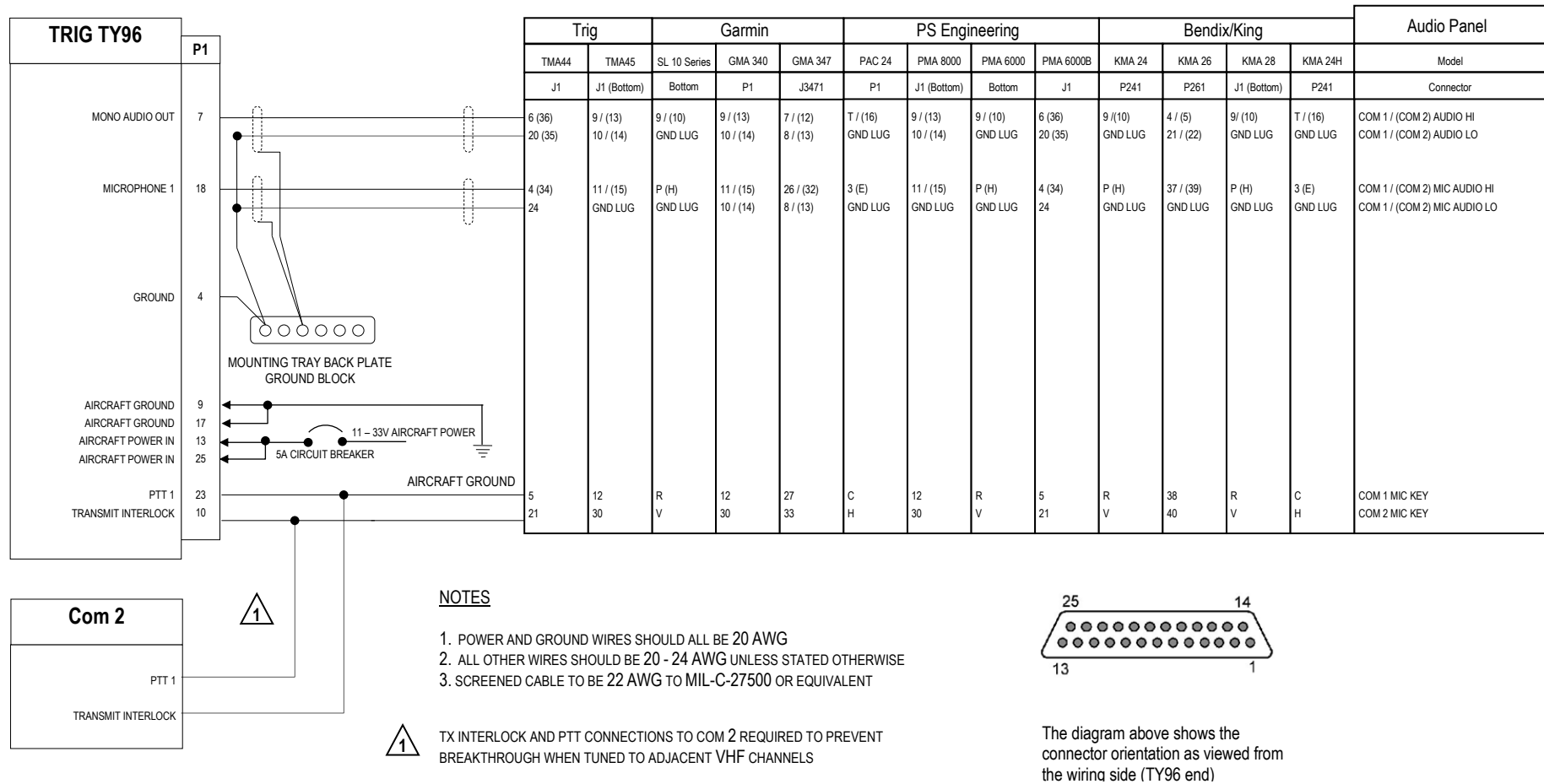
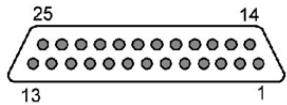
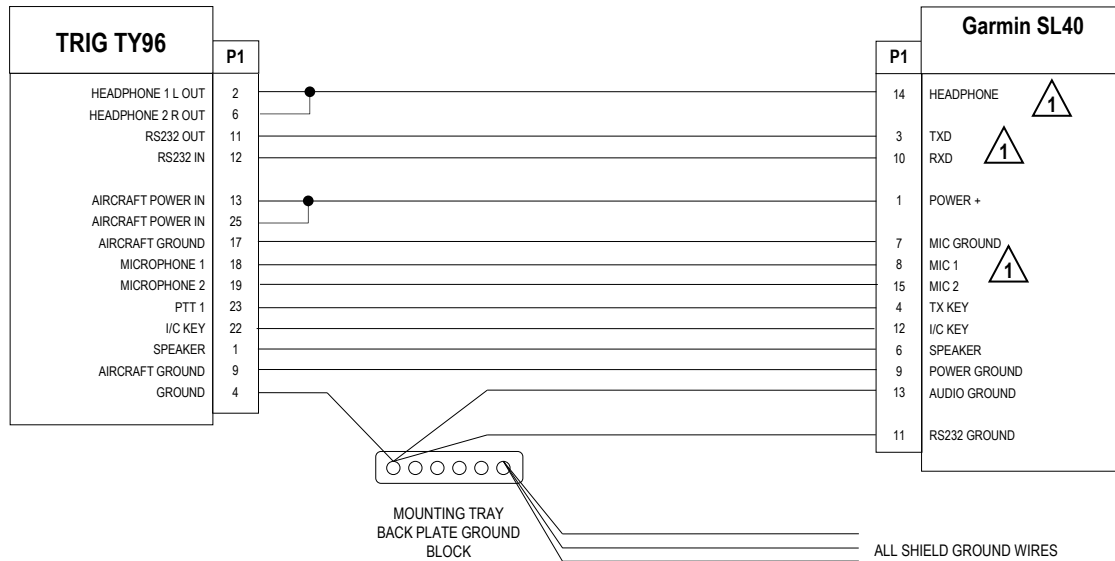
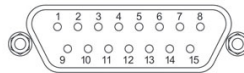

Diagram 3: Audio panel interconnect



The diagram above shows the connector orientation as viewed from the wiring side (TY96 end)



The diagram above shows the connector orientation as viewed from the wiring side (SL40 end)

NOTES

THIS DIAGRAM ILLUSTRATES HOW TO USE THE EXISTING WIRING FROM A GARMIN SL40.

1. POWER AND GROUND WIRES SHOULD ALL BE 20 AWG
2. ALL OTHER WIRES SHOULD BE 20 - 24 AWG UNLESS STATED OTHERWISE
3. HEADPHONE OUTPUTS 1L & 2R ARE SHORTED TOGETHER TO PROVIDE A CONSTANT SIGNAL LEVEL – 1L & 2R REMAIN AT THE SAME VOLUME DURING 2D AUDIO POSITIONING

1 THESE CONNECTIONS SHOULD ALREADY BE WIRED USING SCREENED CABLE. THIS DIAGRAM ONLY ILLUSTRATES THE EXPOSED WIRING INSIDE THE SHIELD. THE SHIELD SHOULD BE CONNECTED TO THE TY96 GROUND BLOCK

2 ALL EXISTING SL40 SHIELD CONNECTIONS SHOULD BE CONNECTED TO THE TY96 GROUND BLOCK

Diagram 4: Connections for existing SL40 wiring replacement

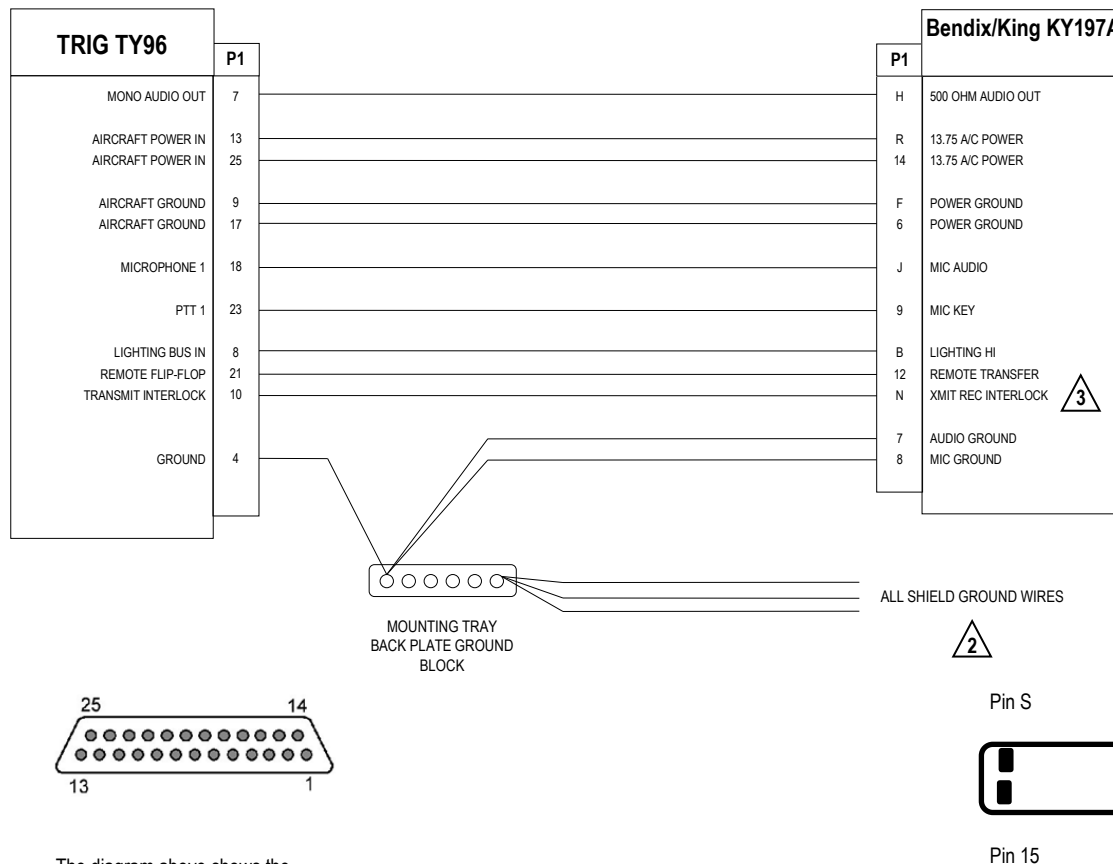

NOTES

THIS DIAGRAM ILLUSTRATES HOW TO USE THE EXISTING WIRING FROM A BENDIX KING KY197A WHICH IS CONNECTED TO AN AUDIO PANEL.

1. POWER AND GROUND WIRES SHOULD ALL BE 20 AWG
2. ALL OTHER WIRES SHOULD BE 20 - 24 AWG UNLESS STATED OTHERWISE

1 THESE CONNECTIONS SHOULD ALREADY BE WIRED USING SCREENED CABLE. THIS DIAGRAM ONLY ILLUSTRATES THE EXPOSED WIRING INSIDE THE SHIELD. THE SHIELD SHOULD BE CONNECTED TO THE TY96 GROUND BLOCK

2 ALL EXISTING SHIELD CONNECTIONS SHOULD BE CONNECTED TO THE TY96 GROUND BLOCK

3 IF REPLACING A KY196, PLEASE NOTE THAT THE FOLLOWING PINOUT IS DIFFERENT:

- LIGHTING HIGH PIN: 1
- REMOTE TRANSFER PIN: 11
- XMIT REC INTERLOCK PIN: M

The diagram above shows the connector orientation as viewed from the wiring side (TY96 end)

Diagram 5: Connections for existing KY197A wiring connected to an audio panel

14. USB File Format

The TY96/TY97 radio internal database that can store up to 250 airfield frequencies. These are stored as an identifier (up to 6 characters), a standard facility designator, such as TWR or GND, and the station frequency. These database entries can be created, edited, and deleted from the front panel of the radio. They can also be saved to a USB stick and loaded from the USB stick.

The data file used on the USB stick is a standard format called Comma Separated Values or CSV, and the USB stick itself uses the popular FAT32 file system, which means that the file can also be edited on a desktop computer. CSV files can be edited using a simple text editor, or they can be opened by most spreadsheet software.

The Trig Com radio database is always loaded from and stored to a file called TRIGCOM.CSV located in the root directory of the USB stick.

Each database record is written to a single line of the file, and is in the following format:

<AIRFIELD>,<FACILITY>,<FREQ>

For example:

EDINBR,TWR,118.700

The airfield name can be up to 6 characters long. If a file is loaded with entries longer than 6 characters, the names will be truncated.

The facility is one of the following:

Standard Form	Alternate Form
TWR	TOWER
GND	GROUND
ATIS	ATIS
ATF	ATF
APPR	APPROACH
ARRV	ARRIVAL
AWS	AWS
CLRC	CLEARANCE
CTAF	CTAF
DPRT	DEPART
FSS	FSS
RFSS	RFSS
UNIC	UNICOM
MNDF	MANDATORY
CTRL	CONTROL
RADR	RADAR
ZONE	ZONE
TALK	TALKDOWN
INFO	INFORMATION
RDIO	RADIO

Frequencies are written in the usual manner; the MHz number should be between 118 and 137 MHz, whilst the kHz value should normally contain 3 digits, although trailing zeroes can be omitted.

14.1 USB Compatibility

Although intended as a generic USB interface, not all memory sticks will work in the TY96/TY97. A Trig branded USB stick is supplied with each radio; the Trig USB stick will work correctly.

The Trig USB stick also has a read-only partition that contains a copy of this manual.

The USB socket is not intended for other functions, and is disabled during normal operation of the radio. It cannot be used as a charging point for other equipment.